

Fire Mitigation for Distribution:

Achieve Quick Progress With Advanced Technology Solutions

This paper describes strategies and technologies designed to minimize or even prevent the threat of electric power-induced fires. These solutions are focused on distribution protection equipment that can be quickly applied to high fire risk areas.

Anthony Rahiminejad and Daqing Hou
Schweitzer Engineering Laboratories, Inc.

Nick Nakamura and Manoj Bundhoo
G&W Electric

In recent years, the electrical power system has increasingly been the source of wildfire ignition. Environmental factors (e.g., climate change, increased temperatures, dry air and land, and high winds) combined with the arcs generated by electric power system equipment significantly increase the risk of wildfire.^{1,2} To ensure public safety, it is vital to plan, prepare and identify solutions for fire mitigation. Electric utilities implement fire mitigation strategies during high fire risk conditions through preventive maintenance, strategic operational practices, enhanced system protection and system hardening.³

Strategic operational practices range from selective relay protection schemes to more extreme, fail-safe measures such as Public Safety Power Shutoff (PSPS) de-energization programs.

Selective relay schemes may include reclose blocking, fast fuse curves and more sensitive ground fault protection, while PSPS shuts off power to the high fire risk area and sectionalizes the perimeter of the unaffected area.

Enhanced system protection reduces the likelihood of ignition through technological advancements such as fast fault clearing schemes, downed conductor detection and communications-assisted system automation.

System hardening strategies help create a more robust, fire-resistant grid by upgrading aging infrastructure to mitigate and eliminate ignitions caused by sparks.

This paper provides a comprehensive review of distribution protection technologies available today for fire mitigation. These solutions are summarized in the Appendix table.

¹ A. Borunda, "See How a Warmer World Primed California for Large Fires," *National Geographic*, November 2018. Available: <https://www.nationalgeographic.com/>.

² Center for Climate and Energy Solutions, "Wildfires and Climate Change." Available: <https://www.c2es.org/content/wildfires-and-climate-change/>.

³ State of California, "Utility Wildfire Mitigation Plans (SB 901)," May 2019. Available: <http://cpuc.ca.gov/SB901/>.

Scope of Fire Mitigation Strategies

Many different strategies comprise a comprehensive fire mitigation program. These strategies touch on nearly every aspect of an electric utility, from operations and infrastructure to personnel readiness and enterprise-wide risk assessment. An in-depth discussion of all of the strategies employed by electric utilities to prevent wildfires is outside the scope of this paper, but they can be grouped into the four categories listed below.

1 Preventive Maintenance

Constant inspection and repair of aging power system infrastructure minimizes the risk of ignition in high fire risk areas. Inspections of distribution poles, transmission structures, pole-mounted equipment and substations should be conducted to identify potential risks. A proactive vegetation management program is also critical in high fire risk areas. Such programs typically include the trimming and removal of trees and other fuel sources.

2 Strategic Operational Practices

A critical component of wildfire mitigation is the ability to assess and forecast the fire risk based on weather conditions and other environmental factors. These variables are dynamic, and accurate forecasting requires processing a large amount of data from multiple sources. The National Weather Service and other organizations provide information on fire risk for different areas. However, many utilities in high fire risk areas deploy their own weather stations and other sensors to collect information on wind speed, temperature, humidity and other factors to determine the fire risk and make decisions regarding the operation of the power system.

3 Enhanced System Protection

Centralized aggregation of data from power system assets provides visibility into the state of the power system so that operators can quickly adjust protection and control to match fire risk conditions. This allows utilities to rapidly disable reclosing or, in extreme cases, shut off power in response to an increased fire hazard in accordance with established procedures. Advanced relay protection algorithms to detect broken and downed conductors can be deployed to speed up isolation of these circuits in cases where traditional protection is slow or ineffective.

4 System Hardening

Hardening power system lines, poles and other equipment through updated designs and material selections allows the power system to withstand higher wind speeds and other environmental factors. System hardening often focuses on pole or line loading, the prevention of equipment flashover and equipment resilience during fire exposure. Examples of system hardening include the replacement of wooden poles with metal poles, insulating overhead conductors, increasing conductor spacing and selectively burying circuits.

This paper provides an overview of existing technologies that can be applied to enhance system protection and harden power distribution systems to mitigate wildfire risks.

Enhanced System Protection

Downed conductor detection

Downed electrical conductors pose a public safety risk due to the possibility of human contact with the conductors and the potential for arcing to ignite wildfires. Downed or fallen conductors are overhead conductors that have contacted the ground or objects connected to the ground. Downed conductors are typically broken conductors. However, damaged poles or other infrastructure can also result in downed conductors that still connect downstream loads to the source, as shown in Figure 1. In extreme cases, changes to the ground itself, such as sand dune movements, can also cause power conductors to come into contact with the ground, resulting in a downed conductor situation.



Figure 1: Downed Conductor

Broken conductors, sometimes known as open conductors, are overhead power conductors that are disconnected between the source and load. Broken conductors that fall on the ground also become downed conductors, as shown in Figure 2. However, not all conductor breaks result in a downed conductor. Broken conductors can tangle with other equipment in the air and never touch the ground, as is the case with a broken jumper (see Figure 3).



Figure 2: Downed Broken Conductor

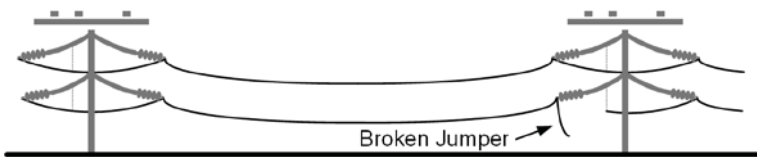

Figure 3: Broken Conductor That Is Not Downed

Sources of high-impedance faults

Live, downed conductors create high-impedance faults (HIFs). HIFs are power system faults that generate very little fault current (typically less than 100A). When a downed conductor lies on a poorly conductive surface, the resulting HIF presents a unique challenge for conventional distribution system protection. Most power distribution systems use overcurrent protection (e.g., relays, recloser controls and fuses) to detect and clear faults. However, the low current of an HIF makes it difficult for overcurrent protection to distinguish the HIF from normal load current and typical system standing unbalance.

Technology available in SEL relays and recloser controls can detect HIFs resulting from downed energized conductors so that appropriate action can be taken to quickly isolate these circuits. The SEL-651R Advanced Recloser Control easily integrates with G&W Viper® reclosers and is available with SEL Arc Sense™ technology (AST) for detecting HIFs (such as downed conductors).

Downed conductors are not the only source of HIFs on power distribution systems. Dirty insulators and overgrown vegetation brushing overhead power conductors can also result in HIFs. The Venn diagram in Figure 4 shows the relationship between open conductors, downed conductors and HIFs.

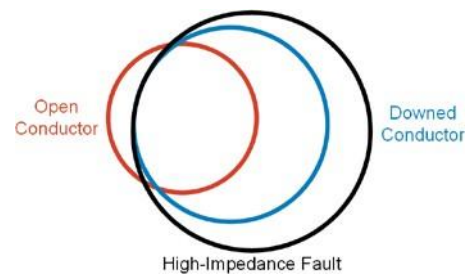

Figure 4: HIFs vs. Downed Conductors

Enhanced System Protection (continued)

HIF detection

HIFs are characterized by their fault current levels. Whether traditional overcurrent elements can detect these faults largely depends on the distribution system configuration. During normal system operations, the distribution system contains a residual current from power apparatus asymmetry and single-phase loads. The standing unbalance resulting from this residual current can be large on multigrounded four-wire systems due to single-phase loads or can be small on three-wire systems without single-phase loads. Traditional overcurrent elements need to avoid tripping on the maximum standing unbalance. The system standing unbalance therefore determines the ability of traditional overcurrent elements to detect HIFs.

For HIFs on multigrounded systems, an alternative to using current magnitude is required to effectively detect HIFs. The AST HIF-detection algorithm available in SEL relays and the SEL-651R effectively detects the arcing caused by downed conductor HIFs, regardless of whether or not a break has occurred. Instead of looking for a change in the overall current or negative-sequence current, the AST algorithm measures the current at interharmonic frequencies

to detect arcing on the system. The AST autotunes to the ambient characteristics of the interharmonic energy on a feeder, extracts signatures of electrical arcing when a fault occurs, and uses traditional timer and counter logic to provide HIF indications.

Applying AST in the SEL-651R allows distribution operators to isolate the line section closest to the downed conductor rather than de-energizing the entire feeder. This protection functionality can be easily added to existing SEL-651R Recloser Controls with a firmware upgrade. Using HIF detection at SEL-651R Recloser Controls throughout the power distribution system increases the protection sensitivity to downed conductors by putting protection closer to HIFs.

The effectiveness of HIF detection is based on many factors, including the type of surface a conductor comes into contact with (e.g., HIFs on asphalt or dry sand are nearly impossible to detect). Table 1 illustrates the relative effectiveness of AST based on the type of ground surface as observed across multiple field tests.

HIGH-IMPEDANCE SURFACE	DETECTION		
	GOOD	BETTER	BEST
Earth	[Green bar spanning all three columns]		
Tree	[Green bar spanning all three columns]		
Gravel	[Green bar for GOOD]		
Concrete	[Green bar for GOOD]		
Sand	[Green bar for GOOD]		

Table 1: Effectiveness of AST HIF Detection Based On Contact Surface Type

Open phase detection

A simple method for detecting an open phase condition that may be due to a broken conductor is to monitor the ratio of negative-sequence to positive-sequence current. Under normal operating conditions, there is little negative-sequence current when single-phase loads are sufficiently balanced. However, for an open phase condition, such as that resulting from a broken conductor, the resulting unbalance will result in an increase in the measured negative-sequence current. The negative-sequence current will be equal to the positive-sequence current for the affected circuit.

Dividing the negative-sequence current by the positive-sequence current provides the current unbalance percentage at a given point in the system. Alarm and tripping thresholds can be set for certain levels of unbalance measured at SEL-651R Reclosers Controls throughout the distribution system. These pickups can be used in conjunction with AST to help determine if a detected high-impedance fault is the result of a broken conductor.

Typical and worst-case system unbalance for different operating conditions must be taken into account when setting these thresholds. This method will not be able to distinguish between a broken conductor and a blown fuse, and may not be sensitive enough to detect a broken conductor on a lightly loaded circuit or lateral. For areas where only single-phase loads are fed and it is desirable to continue operation for a single blown fuse, this method alone is not sufficient to detect broken conductors.

Enhanced System Protection (continued)

Integrating system-level downed conductor detection

Downed conductor protection is best implemented as part of an overall system. AST in SEL relays and the SEL-651R can provide the backbone of such a system for detecting HIFs from downed conductors. Integrating these devices into SCADA or a centralized distribution automation controller improves the sensitivity and security of this protection by incorporating data from other sources, such as the SEL-FLT and SEL-FLR Fault and Load Transmitter and Receiver System. Concentrating this information allows a SCADA operator to quickly take actions based on all relevant information, and it allows a distribution automation controller to make automatic, high-speed trip and alarm decisions based on data from multiple devices in various protection zones. Refer to Figure 14 in the Appendix for a high-level example of such a simple, integrated system.

Qualifying HIF detection

In applications with dynamic system conditions, it may be necessary to qualify tripping decisions from HIF elements with additional data from the power system. If communications are available to the SEL-651R, the sensitivity and security of HIF detection can be balanced with information from SCADA and other systems. When advanced metering infrastructure data are available to SCADA in near-real time, the loss of meters at locations downstream of a recloser combined with the assertion of the SEL 651R HIF element at that recloser can provide a high degree of confidence that there is a downed, broken conductor.

A sudden loss of load current on one phase that is measured at a tap or lateral can also serve as qualification for the HIF element of an upstream SEL-651R, which can trip or alarm on a downed, broken conductor. This can be easily achieved by applying the SEL-FLT and SEL-FLR System at taps and laterals downstream of reclosers in high fire risk zones to indicate a loss of current to SCADA or a centralized distribution automation controller.

The SEL-FLT and SEL-FLR System can quickly indicate a fault, loss of current or disturbance, and report accurate load data to give distribution system operators better visibility into system conditions and speed up fault location. The SEL-FLT can be easily installed on overhead conductors with a single hot stick. It communicates with the SEL-FLR, which then provides data over DNP3 to SCADA. Figure 5 shows an example application.

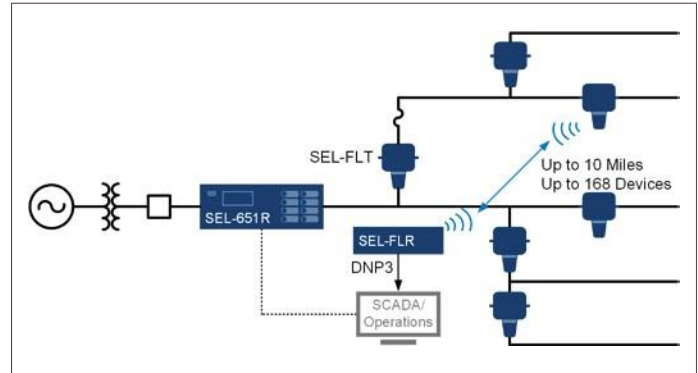

Figure 5: Example SEL-FLT and SEL-FLR Application

The SEL-FLT can distinguish between permanent and momentary faults or losses of load in applications where automatic reclosing is applied. An individual counter is kept for each type of event, which can aid in identifying the location of momentary faults or other problematic areas. A high number of momentary faults on a lateral may indicate a point of impending failure or the need for additional vegetation management.

Figure 6 shows how the SEL-FLT identifies different event types. Separate programmable timers are used for faults and losses of load to distinguish between permanent and momentary events.

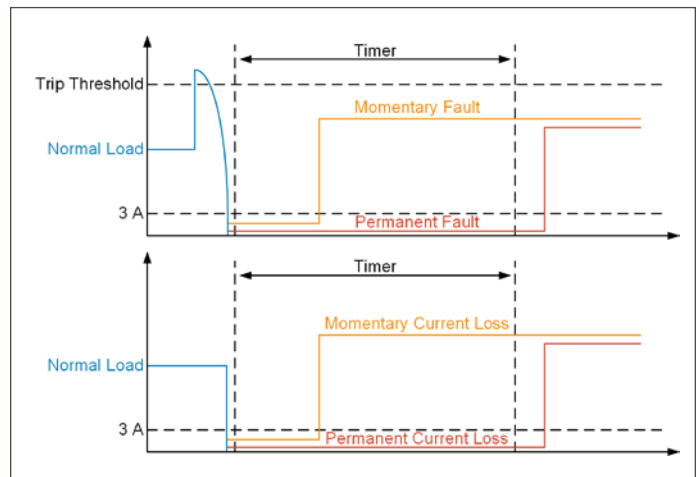

Figure 6: SEL-FLT Event Detection

Enhanced System Protection (continued)

Falling conductor detection

SEL worked with a California utility to develop a novel approach to quickly detect and trip for a falling conductor before it even hits the ground.⁴ This application monitors voltage synchrophasor data measured by phasor measurement units (PMUs) at locations throughout the power system and checks for voltage change patterns between locations to detect a conductor break. When it detects a conductor break, it uses high-speed IEC 61850 GOOSE messaging to issue trip commands to isolate the falling conductor. This application requires high-speed, large-bandwidth communications between PMUs as well as voltage measurements at both ends of all protected line segments.

Adaptive reclosing

Electric utilities use automatic reclosing to improve system reliability by preventing momentary faults on overhead conductors, resulting in extended outages. However, for circuits that pass through high fire risk areas, automatic reclosing is not desirable due to the increased risk of ignition from repeated arcing. It has become common to disable reclosing on these feeders during certain times of the year, based on weather conditions or altogether in some instances. The flexibility of the SEL-651R allows utilities to easily adapt protection and reclosing schemes to meet the dynamic challenges associated with preventing wildfires.

Remote automatic reclose adjustments

Due to the dynamic nature of weather, environmental and other factors that impact the risk of wildfires, protection schemes must also adjust in real time. The SEL-651R can be easily integrated into a centralized control system (SCADA, distribution management system, etc.) using standard industry protocols via a serial or Ethernet interface. This allows system operators to quickly disable reclosing, sectionalize the high-risk fire areas and adjust other settings manually or automatically based on changing conditions.

Electric utilities collect more data than ever before from multiple systems to maximize efficiency, reliability and safety. Fire risk models derived from weather stations, satellite photos and other data can provide system operators with the information they need to make decisions to disable reclosing or, in extreme

circumstances, shut off power in the interest of public safety. Adjustments to reclosing and protection schemes can be differentiated by circuit and location to adjust to existing and forecasted conditions. Examples of this are remotely disabling reclosing or remotely opening the recloser to sectionalize the perimeter of a high fire risk zone when the existing or anticipated fire risk is elevated due to weather or other conditions.

Dynamic automatic reclose adjustments

By disabling reclosing, utilities are prioritizing public safety over system reliability. In cases where part of a line passes through a high fire risk area, the reliability of the entire feeder can be affected. The SEL-FT50 and SEL-FR12 Fault Transmitter and Receiver System can provide high-speed fault detection information directly to an SEL relay or SEL-651R. The SEL-FT50 Fault Transmitter detects fault current and sends a wireless indication to the SEL-FR12 Fault Receiver, which communicates directly with the SEL-651R via high-speed MIRRORING[®] communications. The SEL-FT50 and SEL-FR12 System is optimized for speed and typically provides fault indications to the SEL-651R within 6 ms of the fault inception. This is fast enough to dynamically change the reclosing or protection scheme of the SEL-651R based on where the fault occurs on the system.

The SEL-FT50 can be easily installed on overhead conductors using a single hot stick. By placing SEL-FT50s at laterals or the boundaries of high fire risk areas, utilities can enable reclosing for faults that occur outside these areas, as shown in Figure 7.

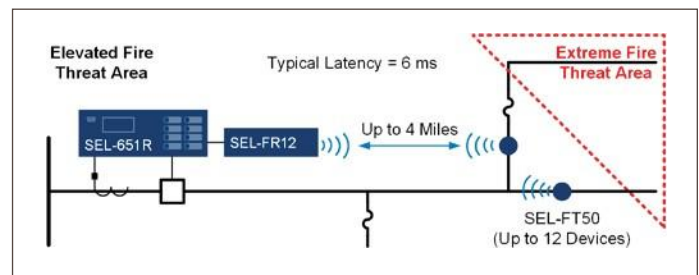

Figure 7: Dynamic Reclosing Application Using the SEL-FT50 and SEL-FR12

Applying the SEL-FT50 and SEL-FR12 System makes it possible for utilities to focus on public safety while reclaiming system reliability for faults in areas where the fire risk is low.

⁴ W. O'Brien, E. Udren, K. Garg, D. Haes, and B. Sridharan, "Catching Falling Conductors in Midair – Detecting and Tripping Broken Distribution Circuit Conductors at Protection Speeds," proceedings of the 69th Annual Conference for Protective Relay Engineers, College Station, TX, April 2016.

Enhanced System Protection (continued)

Fast fault clearing

The speed at which faults are cleared is an important consideration for fire mitigation because the energy released by an arcing fault is proportional to the fault clearing time. The total fault clearing time is the sum of the time needed to identify a fault condition and signal tripping plus the time required for the breaker or recloser control to break the fault current. Electric utilities strive to achieve the fastest clearing times possible while still meeting selectivity and system reliability requirements. For distribution circuits that pass through high fire risk areas, minimizing the arcing duration and total fault energy is critical.

SPEED UP TRIPPING FOR HIGH-RISK LATERALS

For circuits with laterals that pass through areas with extreme fire risk, it may be desirable to speed up tripping. Recloser controls in these areas are typically set to coordinate with lateral fuses, and reclosing is disabled. When fire models forecast an elevated risk for a high-risk fire area, utilities may increase tripping speeds in the area. The SEL-FT50 and SEL-FR12 System can be used to indicate that a fault is on a lateral passing through one of these areas and allow the SEL-651R to trip with no intentional delay. For laterals protected by larger fuses, this method can be used to speed up the fault clearing time and thus lower the total fault energy by intentionally miscoordinating the recloser with the fuse protecting the lateral.

DECREASE PROTECTIVE DEVICE CLEARING TIMES

Once faults are detected, a signal is sent to a breaker or recloser to trip and isolate the fault. There is a fixed time to clear the fault, based on the device, once this trip signal is received. Decreasing the fault clearing time reduces the total arcing duration and energy released by a fault.

A G&W Current Limiting Protector (CLiP[®]) is composed of an interrupter and a high-current limiting fuse, as shown in Figure 8. It is an electronically sensed

and triggered commutating current limiter in which a copper busbar carries the continuous current. This current path is opened under overcurrent conditions to introduce a parallel-mounted current limiting fuse that interrupts the fault. The most effective way to reduce the let-through energy is to reduce the detection and clearing time significantly. By reducing the let-through energy (typically to less than 1% as compared with a five-cycle breaker) and clearing the fault current within half a cycle, the CLiP can be an effective solution to wildfire mitigation. Its ability to interrupt current in less than one cycle greatly reduces the possibility of fault-induced ignitions. The CLiP can be configured to trigger on a user-settable fault current and is suitable for installation inside the substation, outside the substation or on a utility pole.

Enhancements to distribution system protection can be quickly deployed as one strategy in a comprehensive fire mitigation program. The detection and isolation of downed conductors is an important part of this strategy and can be accomplished using AST in the SEL-651R, the SEL-751 Feeder Protection Relay and the SEL-451 Protection, Automation and Bay Control System. AST can be added to existing SEL-651R-2 Recloser Controls in the field to quickly identify and isolate downed conductors in high-risk fire areas. The ability to easily integrate the SEL-FT50 and SEL-FR12 System with new and existing SEL recloser controls allows for the quick deployment of dynamic reclosing schemes and faster tripping across distribution systems.

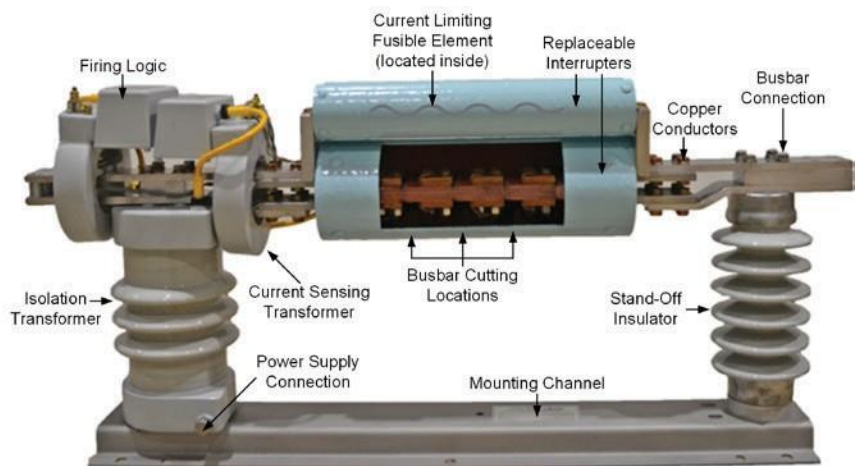

System Hardening

Flashover mitigation

The exposed energized conductors prevalent throughout the overhead grid can produce sparks or flashovers that can ignite wildfires. From system faults to wildlife violating electrical clearances, many different ignition sources need to be taken into consideration. This subsection focuses on system hardening strategies that can mitigate system flashovers.

INCREASED PHASE SPACING

Overhead distribution equipment available today can be custom-engineered to mitigate flashovers. G&W Viper reclosers can provide flexibility with independent pole designs in which each phase has its own fault interrupting mechanism. This enables customizable, extended phase spacing in frame designs that can mitigate phase-to-phase external flashovers. Traditional designs use a 15 inch phase-to-phase spacing, while newer designs extend this to 24, 30 or more inches. This extended spacing helps prevent flashover ignitions caused by vegetation, overvoltage and wildlife contact. According to IEEE standards for electrical clearances,^{5,6} the minimum phase-to-phase spacing for medium-voltage ratings, such as a 38kV maximum system voltage and 150kV basic impulse level, are 10.3 and 12 inches, respectively. Extended phase spacing allows a considerable margin for mitigating electrical clearance-related flashovers.

When pole congestion is an issue and there is limited space to install reclosers, G&W Viper recloser module designs can be configured with a Z-shape that orients both source and load bushings horizontally, as shown in Figure 9. This construction adds a safety margin to electrical clearances to prevent ignitions.



Figure 9: G&W Viper Recloser With Z-Shaped Modules and Extended Phase Spacing

DEAD-TANK CONSTRUCTION

Per IEEE C37.100-1992,⁷ a dead-tank switching device is a vessel in which the “ground potential surrounds and contains the interrupter(s) and the insulating mediums.” A live-tank switching device is defined as a “device in which the vessel(s) housing the interrupter(s) is at a potential above ground.” G&W Viper reclosers are designed with solid dielectric modules that use a fully grounded, dead-tank design. In an overvoltage event that results in a system-induced flashover, a module with a dead-tank design can conduct the fault to the ground potential of the module. This reduces the probability of the flashover propagating from phase to phase and resulting in

a larger flashover. This also reduces the need for external sensors, which in turn reduces exposed live energy sources. A dead-tank design can also mitigate wildlife-induced flashovers by reducing live energy sources.

HIGHER RATED INSULATORS AND THE INTEGRATION OF ELBOW CONNECTORS

The primary connected interfaces of the G&W Viper recloser are designed to the IEEE 386 standard for separable insulated connector systems, making the insulators removable and field upgradable, like the one shown in Figure 10.⁸



Figure 10: G&W Viper Removable, Field-Upgradable Insulators

⁵ IEEE C2-2017, National Electric Safety Code® (NESC), Table 235-6.

⁶ IEEE 1427-2006, IEEE Guide for Recommended Electrical Clearances and Insulation Levels in Air Insulated Electrical Power Substations, Table 3.

⁷ IEEE C37.100-1992, IEEE Standard Definitions for Power Switchgear.

⁸ IEEE 386-2016, IEEE Standard for Separable Insulated Connector Systems for Power Distribution Systems Rated 2.5 kV Through 25 kV.

System Hardening (continued)

G&W Viper reclosers rated at maximum system voltages of 15kV or 27kV can be upgraded with 38kV insulators, which increases creepage and strike distances. Creepage distance is the shortest allowable distance between conductive potentials, considering the path along the sheds of the insulator. Strike distance, or flashover distance, is the shortest straight-line path between potentials. Adding more safety margin to strike and creepage distances reduces the probability of flashovers that can ignite wildfires.



Figure 11: Elbow-Connected G&W Viper Reclosers

In addition to silicone insulators, industry-standard rubber elbow connectors designed with IEEE 386 interfaces can also be connected to applicable recloser interfaces, as shown in Figure 11.

These elbow connectors can combine with dead-tank G&W Viper reclosers to significantly reduce the number of exposed live connections on the overhead line that can be a flashover source. Elbow-connected G&W Viper reclosers have been applied to protect transformers and riser pole overhead-to-underground transitions, and to mitigate wildlife-induced flashovers.



FLAME-RETARDANT WILDLIFE GUARDS

Proper wildlife guard material, designed to fit over exposed energized parts, is extremely important considerations in fire mitigation. Designs that are properly fitted minimize exposure to energy potentials and prevent flashovers caused by animal contact. Flame-retardant wildlife guard materials prevent flashover events from igniting the guards, thus preventing flaming material from dripping on the ground below. Wildlife guards are available that have been custom-fitted for G&W Viper recloser insulators and that comply with IEEE 1656-2010 and UL 94 V-0 flammability ratings.⁹ IEEE 1656-2010 is a standard for testing wildlife protector performance, and the UL 94 V-0 rating tests a material's ability to self-extinguish without dripping flaming particles.

⁹ IEEE 1656-2010, IEEE Guide for Testing the Electrical, Mechanical, and Durability Performance of Wildlife Protective Devices on Overhead Power Distribution Systems Rated up to 38 kV.

System Hardening (continued)

Transition overhead circuits to underground

Another strategy to harden the system and reduce the possibility of a wildfire is to identify high-risk overhead lines and transition them underground. The dead-tank design with IEEE 386 interfaces of G&W Viper reclosers allows them to be used in underground applications, such as in a padmount configuration. The same protection relays and settings used in the overhead application can be used in the underground application, reducing the number of relay part numbers and configurations that need to be managed. G&W Trident® bypass switchgear can also be run in parallel with the recloser to simulate overhead construction, as shown in Figure 12. Additionally, a visible break, such as the Trident with SafeVu™, can be integrated to provide more operator visibility in this configuration.

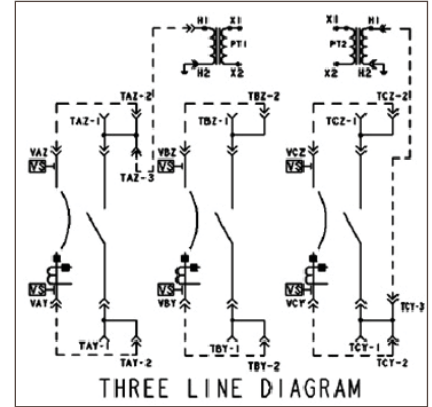

Figure 12: G&W Viper Recloser With G&W Trident Bypass and the Three-Line Diagram

Quick progress with site-ready reclosers

G&W Viper reclosers and SEL recloser controls can be configured as a site-ready system that can speed up the deployment of fire mitigation solutions. These designs incorporate many components needed in the overall recloser installation, as shown in Figure 13. Variability associated with the routing of primary wires or improper installation of lightning arresters in the field can violate electrical clearances and cause a wildfire ignition. With site-ready configurations, G&W engineers install this variability out of the design and install the components in a quality-controlled manufacturing environment. Having all components pre-installed at the factory significantly reduces the amount of time and labor needed for installation. These designs also simplify part sourcing, as G&W can serve as a single supplier for all components.

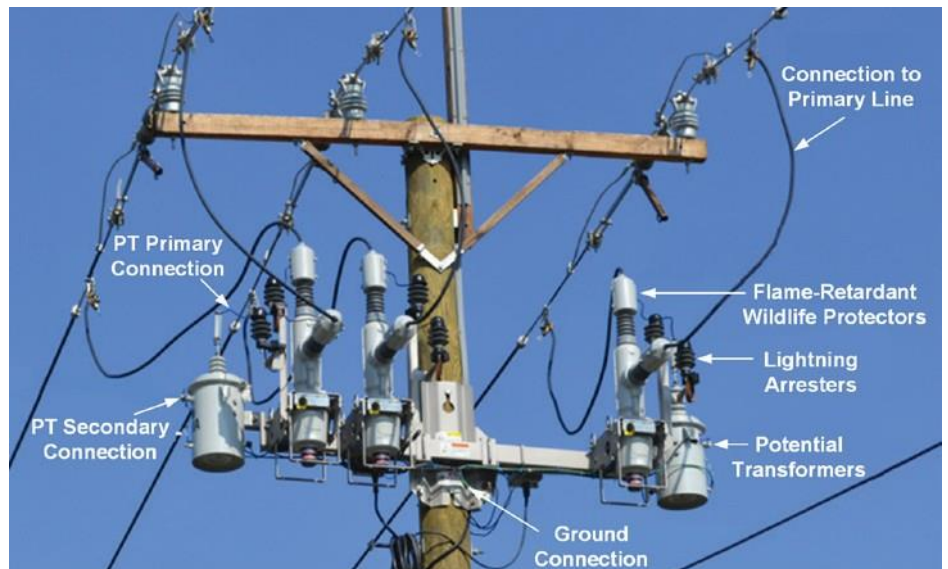

Figure 13: Site-Ready G&W Viper Recloser

Conclusion



Fire mitigation strategies based on enhancing system protection and system hardening are critical in laying the foundation for a fire-resistant grid.

With changing environmental conditions causing increased threats to public safety and infrastructure, advanced technology can be leveraged to mitigate grid-induced ignitions. The distribution protection strategies and solutions discussed in this paper present technologies available today for achieving quick progress toward the fire-resistant grid of tomorrow.

Appendix

Table 2 and Table 3 summarize the various distribution protection solutions discussed in this paper. Figure 14 shows an example of various fire mitigation solutions integrated into a single system.

BENEFITS OF ENHANCED SYSTEM PROTECTION

APPLICATION	SOLUTION	BENEFITS	ACHIEVE QUICK PROGRESS
Downed conductor detection	HIF detection	Detects ground faults that can represent spark-producing downed conductors	Available in new SEL-651R-2 Recloser Controls and as a firmware upgrade for existing SEL-651R-2 Controls
	Open phase detection	Detects an opened conductor that can represent a break in the circuit and a potential ignition source	Easy to implement in any SEL-651R with firmware version R408 or later
	Integrating system-level downed conductor detection	Incorporates data from multiple sources to give SCADA operators visibility to act quickly and to enable centralized control systems to make automatic, high-speed trip decisions in the event of a downed conductor	Easy to implement where SCADA communication is available to the SEL-651R and other field devices; easy to quickly deploy the SEL-FLT and SEL-FLR System to provide additional data points at locations without existing intelligent electronic devices
	Falling conductor detection	Detects falling conductors using high-speed communications, synchrophasors and complex logic, and clears the fault before the falling conductor hits the ground	Available where existing PMUs and high-speed communications are available at both ends of the protected line segment
	Real-time changes via SCADA	Allows SCADA operators to communicate with protective relays and remotely change group settings (e.g., block reclose, fast curve, sectionalizing during de-energization and sensitive earth fault) to prevent fires	Easy to implement in SEL-651R where communication with SCADA is available; communication can be provided by the SEL-3061 Cellular Router where adequate cellular coverage exists
Adaptive reclosing	Real-time changes via fault transmitter data	Uses fault transmitter data to quickly adjust relay tripping and reclosing in real time based on fault location to prevent fires	Easy to add the SEL-FT50 and SEL-FR12 System to existing SEL relays and recloser controls
Adaptive reclosing	Relay protection settings	Change the fault interrupting fuse curve to a faster curve, and use fault transmitter data for selective, intentional miscoordination to minimize the duration of faults, thus reducing the probability of fault-induced ignitions	Easy to implement fast curves in, or add the SEL-FT50 and SEL FR12 System to, existing SEL relays and recloser controls
Fast fault clearing	Current limiting protection technology	Interrupts fault currents at sub-cycle speeds (one-quarter to one-half of a cycle) to reduce the fault current let-through time and minimize the probability of fault-induced ignitions	Available as option on new G&W CLiP packages

Table 2: Achieve Quick Progress with Enhanced System Protection

Appendix

BENEFITS OF SYSTEM HARDENING

APPLICATION	SOLUTION	BENEFITS	ACHIEVE QUICK PROGRESS
Flashover mitigation	Increased phase spacing	Increase electrical clearances with flexible recloser frames and Z-shaped module designs to reduce phase-to-phase external flashovers	Available on new G&W Viper reclosers (24 and 30 inch or greater phase spacing available)
	Dead-tank construction	Minimizes propagation of external flash-over from lightning and wildlife interference by conducting the fault to ground	Included with all G&W Viper-S/ST/SP recloser designs
	Higher rated insulators	Increase creepage and strike distances on removable G&W Viper recloser insulators to reduce probability of a flashover	An easy upgrade on new or existing field-installed G&W Viper reclosers; retrofit packages are available
	Integration of elbow connectors	Eliminates exposed live connections that can be a potential flashover source	An easy upgrade on new or existing field-installed G&W Viper reclosers
	Flame-retardant wildlife guards	Prevent flashovers from wildlife contact with flame-retardant wildlife guards compliant with IEEE 1656 and UL 94V-0	An easy upgrade to existing field-installed G&W Viper reclosers
Transition overhead circuits to underground	Padmount reclosers	Eliminate exposed overhead conductors in high fire risk areas with fully grounded, dead-tank G&W Viper reclosers (the same relay can be utilized for overhead and underground applications)	Available on new G&W Viper reclosers
	Padmount reclosers with integrated isolation and bypass switches	Replicate overhead configurations with padmount G&W Viper reclosers, Trident bypass switchgear and Trident with SafeVu visible break isolation switchgear	Available on new G&W Viper, Trident and Trident with SafeVu combination switchgear
Quick progress with site-ready reclosers	Site-ready designs	Incorporate G&W recloser and SEL control components into one design to speed up the deployment of the fire mitigation solution	Available on new G&W Viper reclosers

Table 3: Achieve Quick Progress with System Hardening

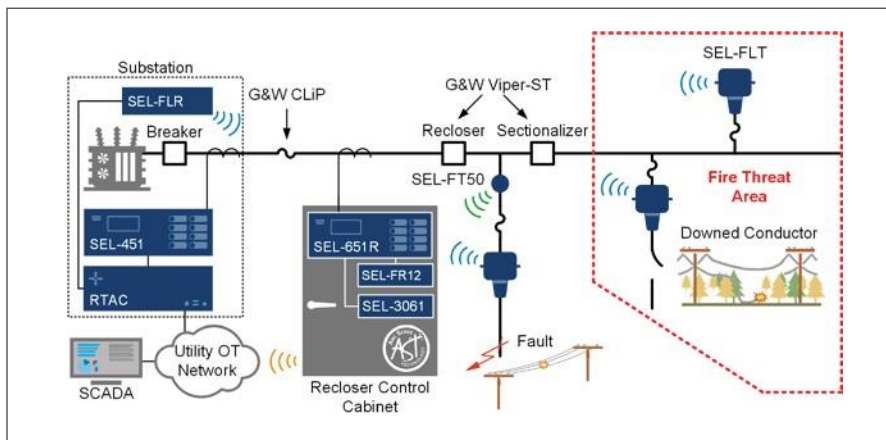

Figure 14: Fire Mitigation System Applications

Appendix

BIOGRAPHIES

ANTHONY RAHIMINEJAD is a lead product sales manager at Schweitzer Engineering Laboratories, Inc. (SEL) in the distribution controls and sensors group. He joined SEL in 2015 as an industrial solutions engineer and has since held roles as an application engineer and as a sales engineer. Prior to joining SEL, he held a position as a senior power system engineer for Eaton Engineering Services. Anthony received his B.S.E.E. degree from North Carolina State University and is a registered professional engineer in the state of North Carolina.

DAQING HOU received B.S.E.E. and M.S.E.E. degrees at the Northeast University, China, in 1981 and 1984, respectively. He received his Ph.D. in Electrical and Computer Engineering at Washington State University in 1991. Since 1990, he has been with Schweitzer Engineering Laboratories, Inc., where he has held numerous positions, including development engineer, application engineer, research and development manager, and principal research engineer. He is currently the research and development technical director for East Asia. His work includes power system modeling, simulation, signal processing and advanced protection algorithm design. His research interests include multivariable linear systems, system identification and signal processing. Daqing holds multiple patents and has authored or coauthored many technical papers. He is a senior member of IEEE.

MANOJ BUNDHOO received his B.S.E.E. degree from the University of Kwa-Zulu Natal, South Africa in 1996. Manoj joined G&W Electric in 1999 and is currently a product manager for specialty products (CLiP and cable accessories). At G&W, he previously held positions as application engineer for underground and overhead switchgear, senior application engineer for cable accessories, and application engineering manager for underground and overhead switchgear. Manoj held an earlier engineering role in the transmission group at a power company in South Africa. Drawing from his experience as an application engineer, he transitioned to the role of product manager. He is focused on providing customer solutions using G&W's existing product portfolio as well as innovative new product development and technology.

NICK NAKAMURA received his B.S. in Electronics Engineering from DeVry University in 2002 and joined G&W Electric in 2011. He currently holds the position of product manager for sensors and has previously held positions as product manager for overhead switchgear and senior engineer for aftermarket support. Nick held earlier engineering roles in the printed circuit board, food and pharmaceutical industries. Today, his work is focused on projects associated with new product development. Nick is involved in professional organizations including the IEEE Switchgear Committee and is an IEEE PES member.

© 2019 by G&W Electric and Schweitzer Engineering Laboratories, Inc. All rights reserved.

All brand or product names appearing in this document are the trademark or registered trademark of their respective holders. No G&W or SEL trademarks may be used without written permission. SEL products appearing in this document may be covered by US and Foreign patents. 20190628